



REQUEST FOR QUALIFICATIONS (RFQ)
for
CUSTOM WRAP DESIGN FOR VINE ELECTRIC BUSES
RFQ No. 25-R15

Issued by:
Napa Valley Transportation Authority
on **January 07, 2025**

Deadline for Qualification Submissions:
4:00 p.m. (PST/Local), Friday, January 31, 2025 (PST/Local)

at the
Napa Valley Transportation Authority
625 Burnell Street
Napa, CA 94559

Release of RFQ authorized by:

A handwritten signature in black ink, appearing to read "Kate Miller", is written over a horizontal line.

KATE MILLER, Executive Director

01/03/2025

Date

Dear Proposers:

The Napa Valley Transportation Authority (NVTA) is issuing a Request for Qualifications (RFQ) for Custom Wrap Design for Vine Electric Buses that will result in a fixed amount award made to each finalist(s) chosen for \$750 to go toward material costs and two separate fixed amount awards made to the first place Artist for \$5,000 and the second place Artist for \$1,500. The deadline for art submissions to qualify is scheduled for January 31, 2025. The Finalist(s) chosen will be announced February 14, 2025, with a new deadline for preliminary design submissions being due March 28, 2025. An award agreement will be made for the first place Artist on April 14, 2025, and a placement award to the Artist who comes in second place. The final artwork for the bus wrap design is due to NVTA on May 28, 2025. NVTA invites all artists from the Bay Area and greater Northern California region to submit qualifications in the form of artist samples. Local artists from Napa County, CA will be given a point preference in the initial evaluation phase for their submissions.

Any agreement to be awarded as a result of this RFQ will be awarded without discrimination based on race, color, religion, sex, sexual orientation, race, religious creed, color, national origin, ancestry, denial of family and medical care leave, medical condition (cancer/genetic characteristics) physical handicap, disability (mental or physical) including HIV and AIDS, denial of pregnancy disability leave or reasonable accommodation, marital status, age (40 and above).

To obtain a full copy of the RFQ, please contact NVTA office at (707) 259-8790 or download the document in PDF format from our [NVTA website](#). All inquiries pertaining to this RFQ should be emailed to Renel Coombs, Procurement & Contracts Administrator, at the following email address: rcoombs@nvta.ca.gov .

Deadline for Qualification Submissions is January 31, 2025, no later than 4:00PM (PST/local).

Submissions will be accepted by means of electronic mail (email) addressed as follows:

Kate Miller
Executive Director
Napa Valley Transportation Authority 625 Burnell Street.
Napa, CA 94559

RFQ No. 25-R15

Submissions shall be submitted by means of electronic mail to echarrier@nvta.ca.gov and rcoombs@nvta.ca.gov with the subject titled: "Qualification Submission for RFQ No. 25-R15"

We look forward to receiving your submission.

Sincerely,

Kate Miller
Executive Director

REQUEST FOR QUALIFICATIONS

CUSTOM WRAP DESIGN FOR VINE ELECTRIC BUSES

RFQ No. 25-R15

PROJECT SCHEDULE

RFQ Issue Date	January 07, 2025
Deadline for Qualification Submissions	January 31, 2025, at 4:00PM (PST/local)
Finalist Selections Posted to NVTA website	February 14, 2025
Award Agreement issued to Finalist(s)	February 14, 2025
Deadline for Finalist(s) Preliminary Design Submissions	March 28, 2025, at 4:00PM (PST/local)
Finalist Invoice NVTA for Payment	Following Receipt/Acceptance of Preliminary Design Submission
Artist Awardee Selection(s) Posted to Vine/NVTA website	April 14, 2025
Award Agreement Issued to Selected Artist(s)	April 14, 2025
Due Date to NVTA for Final Artwork	May 28, 2025
Awardees Invoice NVTA for Payment	Following Receipt/Acceptance of Final Product

SECTION I - INTRODUCTION

The Napa Valley Transportation Authority (NVTA) is a joint powers authority established in June of 1998 with members including the cities of American Canyon, Calistoga, Napa, St. Helena, the Town of Yountville, and the County of Napa. The work activities of NVTA are defined by the joint powers agreement and overseen by the Board of Directors made up of elected officials from the respective member agencies, and an ex-officio member from the Paratransit Coordinating Council (PCC).

NVTA serves as the countywide transportation planning body for the incorporated and unincorporated areas within Napa County and is responsible for programming State and Federal funding for transportation projects within the county. NVTA is charged with coordinating short- and long-term planning and funding within an intermodal policy framework in the areas of highways, streets and roads, transit and paratransit, and bicycle improvements.

NVTA also operates the Napa Vine Transit services. Napa Vine provides inter-county/city transit services between Napa Valley Cities, towns and the Counties of Sonoma, Solano, and Contra Costa. Napa Vine Go is the companion paratransit service for Napa County's residents. In addition, the Vine suite of services includes American Canyon Transit, St. Helena Transit, the Yountville Bee-Line, City of Napa On-Demand service, and the Calistoga Shuttle. The fleet consists of 75 vehicles and provides roughly 1,000,000 trips per year prior to COVID (in Fiscal Year 2018-2019) and over 300,000 trips during COVID (in Fiscal Year 2020-2021).

The Napa Valley Transportation Authority (NVTA) is also the local transportation sales tax authority. NVTA is responsible for the oversight and administration of Measure T, the ½% sales tax for street and road improvements approved by the voters on November 6, 2012.

SECTION II – SUBMISSION REQUIREMENTS

1. PROJECT DESCRIPTION:

NVTA is seeking artists interested in designing and submitting artwork to NVTA to be made into a custom bus wrap and publicly displayed on one or more of Vine Transit's new 40' Gillig electric buses. The dimensions of the bus are found in **Attachment A**.

NVTA reserves the right to make one or more awards or no award from this solicitation.

2. THEME:

Artwork should represent the artist's unique perspective and/or style and be conceptualized around the Napa Valley region, community spirit and sustainable living. NVTA is advancing towards its zero-emission goals by acquiring electric transit buses therefore the theme should be one that inspires the community, through art, to embrace Napa Valley's greener transportation methods. Additionally, project must incorporate Vine Transit and NVTA logos.

3. ENTRANT QUALIFICATION

Entrants must be 18 years of age or older unless those persons under the age of 18 are able to show proof of legal guardian consent included with the artwork submission. In the event a person under the age of 18 is selected as a Finalist and/or an Awardee, the Agreement and payment will be made to the legal guardian of the Artist.

4. SUBMISSION REQUIREMENTS:

Each phase of submissions must be sent by email to: Emily Charrier, Communications and Outreach Coordinator: echarrier@nvta.ca.gov and Renel Coombs, Procurements & Contracts Administrator: rcoombs@nvta.ca.gov by the Deadline for Submissions dates stated in the Project Schedule, page 3.

PHASE I: ART SAMPLES

1. One (1) page letter of introduction for the Artist and for each work submission. Introduction must include:
 - a. Name
 - b. Address

- c. Contact Information
2. No more than ten (10) digital images of Artist's original artwork that are representative of the Artist's capability to qualify for this project.
3. An additional one (1) page description of the digital images submitted to include:
 - a. Title
 - b. Media
 - c. Size
 - d. Date
4. If Artists experience trouble submitting their digital images and/or the digital images exceed 20MB, Artists must email to Emily Charrier, Communications and Outreach Coordinator, at echarrier@nvta.ca.gov, who will provide a Dropbox link.

PHASE II: PRELIMINARY DESIGN

1. One (1) page letter of introduction to Artist and for work submission.

Introduction must include:

- a. Name
 - b. Address
 - c. Contact Information
2. Digital image of original artwork based upon the project theme, as described in Section II, 2. Theme.

5. WITHDRAWAL OF SUBMISSION:

An Artist may withdraw its submission at any time before the Deadline for Submissions dates stated in the Project Schedule, page 3, of this RFQ, by sending an email to: Renel Coombs, Procurement and Contracts Administrator, at: rcoombs@nvta.ca.gov.

6. SELECTION PROCESS:

The selection process will consist of two (2) phases that are aligned with the submission phases.

1. Phase I:

- a. Phase I includes Artist(s) submitting artwork samples using the instructions provided in Section II, 4, Phase I: Art Samples.
- b. Up to, but no more than, three (3) finalists will be selected based upon scoring criteria below:

Evaluation Factor	Scoring Criteria
Napa Valley (Local) Artist	5%
Quality of Submissions	25%
Knowledge and Use of Media Required	25%
Overall Visual Appeal	45%
TOTAL	100%

- c. Selection of Finalist(s) will be made from the Phase I selection process and the results will be posted to the project solicitation page of NVRTA's website. An email will also be sent to all Entrants with scores received and selection results, in accordance with the Project Schedule, Page 3 of this RFQ. Finalist selection results will be posted to NVRTA's website without the scores received.
- d. No payment will be made for entries made during this phase.

2. Phase II:

- a. The Finalist(s) chosen from Phase I will create a preliminary bus wrap design based upon the project theme, Section II., 2. Theme.
- b. Artists notified of their selection will be required to fill out a W-9 Form and sign an Agreement prior to preparing the preliminary design for selection. The Agreement will be made for a fixed amount of seven hundred and fifty dollars (\$750) to be used towards reimbursement of costs for materials and supplies needed to create the preliminary design.
- c. The terms and conditions to the agreement are attached to this RFQ, ATTACHMENT B.
- d. Up to, but no more than, two (2) Artists will be chosen, and a separate Agreement will be made to the Artist(s) selected to prepare the final artwork piece to be installed on Vine Transit Buses.

- e. Evaluation of Phase II artwork will be scored based upon the below criteria:

Evaluation Factor	Scoring Criteria
Artistic Quality and Originality	25%
Community Context	25%
Relevance to Napa Valley Community and Sustainable Transportation	50%
TOTAL	100%

- a. Selection of Awardee(s) will be made from the Phase II selection process and the results will be posted to the project solicitation page of NVTA’s website. An email will also be sent to each Finalist(s) separately with scores received and selection results, in accordance with the Project Schedule, Page 3 of this RFQ. Awardee selection results will be posted to NVTA’s website without the scores received.
- b. Artwork. The designer/vendor agrees to provide NVTA with a vector. It will be in AI, EPS, PDF, and SVG formats as well as a PNG of the winning design. The designer/vendor also agrees to provide additional variations upon request including White Background, Colored Background, Black & White, and Solid Colors. All deliverables are referenced herein as defined as the ("Logo"). Variation requests are required to take place within 2 weeks of selecting a winner.

7. EVALUATION COMMITTEE

The evaluation committee will be made up of a combination of NVTA committee members, employees including Transdev, a contractor of NVTA. The proposed committee consists of:

- a. Napa Valley Transportation Authority Executive Director or designee
- b. One (1) Citizen’s Advisory Committee Member
- c. One (1) Paratransit Coordinating Committee Member
- d. Two (2) Napa Valley Transportation Authority Employees
- e. One (1) Transdev Employee

SECTION III - AWARD

1. AWARD AGREEMENT

Two awards will be made:

Second Place award in the amount of one thousand, five hundred (\$1,500); and,

First Place award in the amount of five thousand (\$5,000), payable upon completion of the final artwork. To receive payment, the Artist(s) will invoice NVTA following acceptance/approval of artwork from NVTA.

The terms and conditions to the agreement are attached to this RFQ, ATTACHMENT B.

2. ARTWORK

The designer/vendor agrees to provide NVTA with a vector .file in AI, EPS, PDF, and SVG formats as well as a PNG of the winning design. The designer/vendor also agrees to provide additional variations upon request including: White Background, Colored Background, Black & White, and Solid Colors. All deliverables are referenced herein as defined as the ("Logo"). Variation requests are required to take place within 2 weeks of selecting a winner.

3. REPRESENTATION

The designer/vendor represents that, other than materials provided to the designer/vendor from the buyer, the artwork is a wholly original work and was not copied in part or whole from an existing Logo or work or otherwise violates any intellectual property law or any other law or right belonging to a third party. The designer/vendor represents that they are the sole author or owner of the artwork, and that the artwork does not violate any patents, trademarks, service or copyrights of another person, firm, or entity.

4. TRANSFER OF OWNERSHIP

The designer/vendor, upon purchase, thereby irrevocably transfers all rights, ownership, intellectual property interest and legal title of the artwork to the buyer. The designer/vendor will not use the design of the artwork in any further or derivative work (except for display as an example of the designer's work for portfolio purposes except as indicated herein) nor offer to resell the artwork to anyone else as NVTA obtains sole and exclusive ownership to the artwork upon purchase: it cannot be resold.

ATTACHMENT A

REVISIONS					
SYM	DATE	DESCRIPTION	REL.	DATE	
A	APG	ISSUED FOR PRODUCTION		1664-10	08/22/22
B	SSS	1. UPDATE SHEET FOR INTERIOR P&ID & CIG. 2. ADD SHEET 3 & 4		1733323	05/26/23

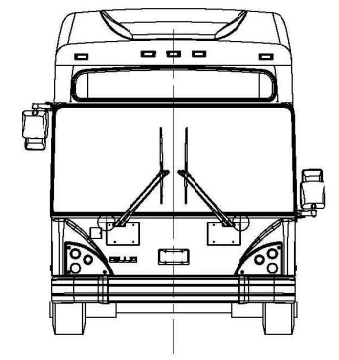
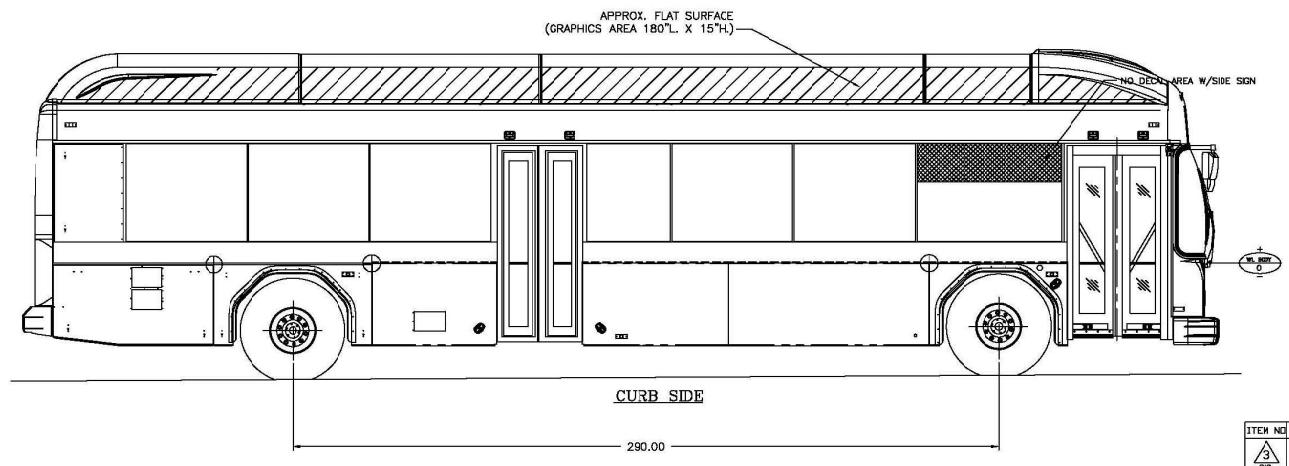
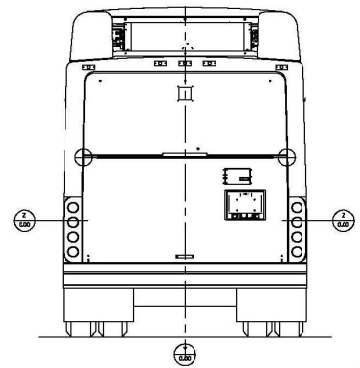
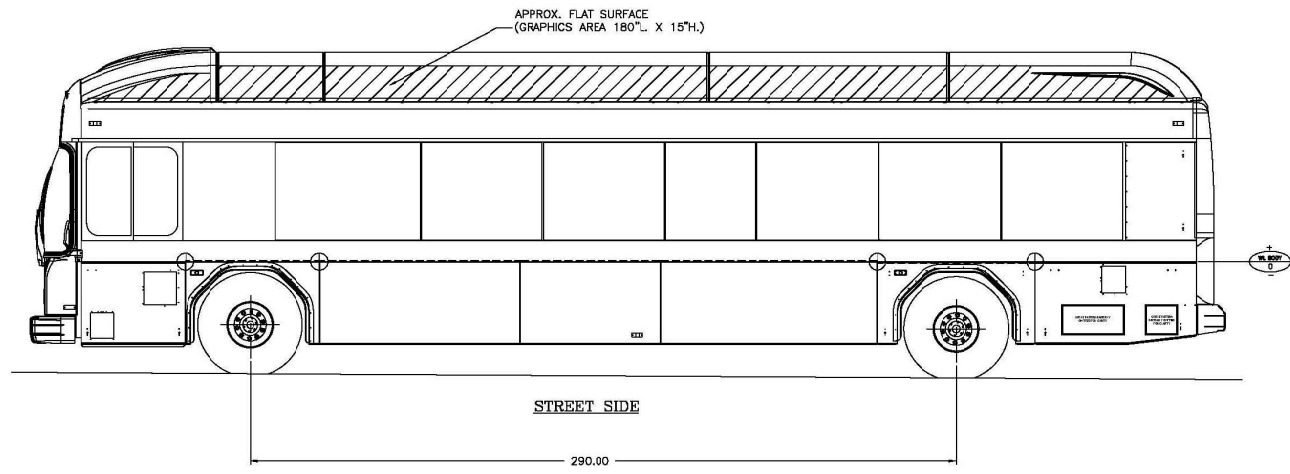

- NOTES:
- FOR DRAWING W/O DIMENSIONS, TURN OFF LAYER DIM.
 - WINDOW SIZES SHOWN ARE FOR OPENING WIDTH, NOT FOR GLAZING SIZE.
 - FOR DRAWING W/O OPTIONS, TURN OFF THOSE LAYERS THAT DON'T APPLY.
 - THIS IS A PRELIMINARY LAYOUT, SOME PANELS MAY CHANGE FOR PRODUCTION.

ITEM NO.	DESCRIPTION	QTY
3	GILLIG L.L.C. LIVERMORE, CA	
<small>PROPRIETARY AND THE INFORMATION CONTAINED HEREIN IS UNCLASSIFIED AND IS THE PROPERTY OF THE GILLIG L.L.C. USE, REPRODUCTION, OR DISSEMINATION OF THE CONTENT OF THIS DRAWING OR ANY PORTION THEREOF FOR ANY PURPOSE MUST BE APPROVED IN WRITING BY THE GILLIG L.L.C.</small>		
<small>REMOVE ALL DIMENSIONS, BREAK SHARP EDGES</small>		
<small>TOLERANCES AND DIMENSIONS ARE FOR UNLESS TOLERANCES UNLESS OTHERWISE SPECIFIED TOLERANCES ARE IN INCHES</small>		
<small>DECIMALS 1/16 1/8 3/16 1/2 3/4 1 1 1/2 2 3 4</small>	<small>ANGULAR ° ' "</small>	<small>THIRD ANGLE</small>
<small>SET 101</small>	<small>ITEM NO.</small>	<small>QTY</small>
<small>MARK PART W/PIN PER GILG DB 4970.002 LH SHAW, RH OPP, FN NONE</small>		
<small>TITLE: LAYOUT, PAINT SCHEME 40 X 102 LF PLUS, EBUS GEN 3.0, W/34" RR DR</small>		
<small>DATE:</small> 08/22/22	<small>APG</small>	<small>APG</small>
<small>DATE:</small> 08/22/22	<small>CNA</small>	<small>STD N3 332</small>
<small>DATE:</small> 08/22/22	<small>166410</small>	<small>10-79308-008</small>
<small>DATE:</small> 1/48 = 1.0	<small>B</small>	

ATTACHMENT B

GENERAL TERMS AND CONDITIONS

1. Compensation.

(a) Rates. In consideration of CONTRACTOR's fulfillment of the promised work, NVTA shall pay CONTRACTOR not to exceed the total amount shown on page 1 (\$_____).

(b) Expenses. No travel or other expenses will be reimbursed.

2. Method of Payment.

(a) Invoices. All payments for compensation and reimbursement for expenses shall be made only upon presentation by CONTRACTOR to NVTA of an itemized billing invoice which indicates CONTRACTOR's name, address, Social Security or Taxpayer Identification Number, itemization of the hours worked or task completed. All claims are to be submitted to NVTA, Accounts Payable, 625 Burrell Street, Napa, CA 94559 or electronically to ap@nvta.ca.gov.

3. **Independent Contractor.** CONTRACTOR shall perform this Agreement as an independent contractor. NVTA shall not deduct or withhold any amounts whatsoever from the compensation paid to CONTRACTOR, including, but not limited to amounts required to be withheld for state and federal taxes. As between the parties to this Agreement, CONTRACTOR shall be solely responsible for all such payments.

4. **Insurance.** CONTRACTOR shall obtain and maintain in full force and effect throughout the term of this Agreement, and thereafter as to matters occurring during the term of this Agreement, the following insurance coverage:

(a) Workers' Compensation insurance. To the extent required by law during the term of this Agreement, CONTRACTOR shall provide workers' compensation insurance for the performance of any of CONTRACTOR's duties under this Agreement, including but not limited to, coverage for workers' compensation and employer's liability and a waiver of subrogation, and shall provide NVTA with certification of all such coverages upon request by NVTA's Risk Manager.

(b) Liability Insurance. CONTRACTOR shall obtain and maintain in full force and effect during the term of this Agreement the following liability insurance coverage's, issued by a company licensed (admitted) to transact business in the State of California and/or having a A.M. Best rating of A VII or better:

1. General Liability. Commercial General Liability [CGL] insurance coverage (personal injury and property damage) of not less than ONE MILLION DOLLARS (\$1,000,000) combined single limit per occurrence, covering liability or claims for any personal injury, including death, to any person and/or damage to the property of any person arising from the acts or omissions of CONTRACTOR or any officer, agent, or employee of CONTRACTOR under this Agreement.

2. Professional Liability/Errors and Omissions. If professional services are rendered by CONTRACTOR, professional liability/errors and omissions insurance for all activities of CONTRACTOR arising out of or in connection with this Agreement in an amount not less than ONE MILLION DOLLARS (\$1,000,000) per claim.

3. Comprehensive Automobile Liability Insurance. If automobiles are used for the services rendered by CONTRACTOR, comprehensive automobile liability insurance (Bodily Injury and Property Damage) on owned, hired, leased and non-owned vehicles used in conjunction with CONTRACTOR's business of not less than ONE MILLION DOLLARS (\$1,000,000) combined single limit per occurrence.

(c) Certificates. All insurance coverages referenced in 4(b), above, shall be evidenced by one or more certificates of coverage or, with the consent of NVTA's Risk Manager, demonstrated by other evidence of coverage acceptable to NVTA's Risk Manager, which shall be filed by CONTRACTOR with the Executive Director prior to commencement of performance of any of CONTRACTOR's duties.

5. Hold Harmless/Defense/Indemnification.

(a) In General. To the full extent permitted by law, CONTRACTOR shall hold harmless, defend at its own expense, and indemnify NVTA and the officers, agents, employees and volunteers of NVTA from any and all liability, claims, losses, damages or expenses, including reasonable attorney's fees, for personal injury (including death) or damage to property, arising from all acts or omissions of CONTRACTOR or its officers, agents, employees, volunteers, contractors and subcontractors in rendering services under this Agreement, excluding, however, such liability, claims, losses, damages or expenses arising from the sole negligence or willful acts of NVTA or

NVTA

its officers, agents, employees, volunteers, or other contractors or their subcontractors. Each party shall notify the other party immediately in writing of any claim or damage related to activities performed under this Agreement. The parties shall cooperate with each other in the investigation and disposition of any claim arising out of the activities under this Agreement, providing that nothing shall require either party to disclose any documents, records or communications that are protected under peer review privilege, attorney-client privilege, or attorney work product privilege.

(b) Employee Character and Fitness. CONTRACTOR accepts responsibility for determining and approving the character and fitness of its employees (including volunteers, agents or representatives) to provide the services required of CONTRACTOR under this Agreement, including completion of a satisfactory criminal/background check and period rechecks to the extent permitted by law if requested by the NVTA. Notwithstanding anything to the contrary in this Paragraph, CONTRACTOR shall hold NVTA and its officers, agents and employees harmless from any liability for injuries or damages resulting from a breach of this provision or CONTRACTOR's actions in this regard.

6. **Termination.** This Agreement may be terminated by either party for any reason and at any time by giving prior written notice of such termination to the other party by giving at least ten(10) days prior to the effective date.

7. **Notices.** All notices required or authorized by this Agreement shall be in writing and shall be delivered in person (by email: ap@nvta.ca.gov) or by deposit in the United States mail, by certified mail, postage prepaid, return receipt requested.

8. **Amendment/Modification.** Except as specifically provided herein, this Agreement may be modified or amended only in writing and with the prior written consent of both parties.

9. **Interpretation; Venue.** The headings used herein are for reference only. The terms of the Agreement are set out in the text under the headings. This Agreement shall be governed by the laws of the State of California without regard to the choice of law or conflicts. This Agreement is made in Napa County, California. The venue for any legal action in state court filed by either party to this Agreement for the purpose of interpreting or enforcing any provision of this Agreement shall be in the Superior Court of California, County of Napa, a unified court.

10. **Compliance with Laws.** CONTRACTOR shall observe and comply with all applicable Federal, State and local laws, ordinances, and codes.

11. **Authority to Contract.** CONTRACTOR and NVTA each warrant hereby that they are legally permitted and otherwise have the authority to enter into and perform this Agreement.

12. **Covenant of No Undisclosed Conflict.** The parties to the Agreement acknowledge that they are aware of the provisions of Government Code section 1090, et seq., and section 87100, et seq., relating to conflict of interest of public officers and employees. By executing this Agreement, the Executive Director hereby determines in writing on behalf of NVTA that CONTRACTOR has been hired to perform a range of duties so limited in scope as to not be required to comply with the Political Reform Act form 700 disclosure obligations of section 87100 et seq.

13. **Attorney's Fees.** In the event that either party commences legal action of any kind or character to either enforce the provisions of this Agreement or to obtain damages for breach thereof, the prevailing party in such litigation shall be entitled to all costs and reasonable attorney's fees incurred in connection with such action.

14. **Entirety of Contract.** This Agreement, including any documents expressly incorporated by reference whether or not attached hereto, constitutes the entire agreement between the parties relating to the subject of this Agreement and supersedes all previous agreements, promises, representations, understandings and negotiations, whether written or oral, among the parties with respect to the subject matter hereof.